

**SCHEDULE OF ALL TYPES OF BEAM :-**

BEAM MKD.	BEAM SIZE (bxd)	REINFORCEMENT					
		SUPPORT		SPAN		STIRRUPS	
		TOP	BOTTOM	TOP	BOTTOM	NEAR SUPPORT	SPAN
RB1	250 X 450	3-16 Ø T + 2-16 Ø T	2-16 Ø T	3-16 Ø T	2-16 Ø T + 2-16 Ø T	2L-8 Ø @ 125 C/C	2L-8 Ø @ 175 C/C
RB2	250 X 400	3-16 Ø T	2-16 Ø T	2-16 Ø T	2-16 Ø T	2L-8 Ø @ 150 C/C	2L-8 Ø @ 150 C/C
TB1	250 X 400	2-16 Ø T	2-16 Ø T	2-16 Ø T + 2-16 Ø T	2-16 Ø T	2L-8 Ø @ 125 C/C	2L-8 Ø @ 175 C/C
SGB1	250 X 400	2-16 Ø T	2-16 Ø T + 1-16 Ø T	2-16 Ø T + 1-16 Ø T	2-16 Ø T	2L-8 Ø @ 150 C/C	2L-8 Ø @ 150 C/C
HB1	250 X 350	2-16 Ø T	2-16 Ø T	2-16 Ø T	2-16 Ø T	2L-8 Ø @ 150 C/C	2L-8 Ø @ 150 C/C
MB1	250 X 300	2-12 Ø T	2-12 Ø T	2-12 Ø T	2-12 Ø T	2L-8 Ø @ 150 C/C	2L-8 Ø @ 150 C/C

**SCHEDULE OF ISOLATED FOOTING:-**

FOOTING MKD.	SIZE (A X B)	D	d	REINFORCEMENT	
				MAIN	DISTRIBUTION
F1	2100X2100	325	150	12 Ø T @ 150 C/C	12 Ø T @ 150 C/C
F2	2400X2400	350	175	12 Ø T @ 150 C/C	12 Ø T @ 150 C/C
F3	2700X2700	400	175	12 Ø T @ 125 C/C	12 Ø T @ 150 C/C

**SCHEDULE OF SLABS:-**

SLAB MKD.	SLAB THK.	BOTTOM REINFORCEMENT		EXTRA TOP REINFORCEMENT(CURT)	
		ALONG SHORTER SPAN (ALTH.)	ALONG LONGER SPAN (ALTH.)	ALONG SHORTER SPAN	ALONG LONGER SPAN
S1	120 mm	8 Ø @ 125 C/C	8 Ø @ 175 C/C	8 Ø @ 175 C/C	8 Ø @ 175 C/C
SST	125 mm	ALONG SHORTER SPAN		ALONG LONGER SPAN	
		8 Ø @ 200 C/C		12 Ø @ 150 C/C	
LIFT	175 mm	VERTICAL(MAIN) BOTHSIDE		HORIZONTAL(DIST.) BOTHSIDE	
		10 Ø @ 125 C/C		8 Ø @ 150 C/C	

EACH CORNER OF WALL MUST CONSISTS OF 2-12Ø VERTICAL BAR THROUGHOUT IN BOTH ADJACENT SIDES

**COLUMN CHART CONCRETE GRADE = M20:-**

SL. NO.	COLUMN MKD.	GR.-1ST. FL.	2ND. FL.	AB. ROOF	TIE BAR ARRANGEMENT
BINDERS 4L-8 Ø @ 200 C/C					
1.	C5,C8,C11,C14 (250 X 450)	12-16 Ø T	12-16 Ø T	12-16 Ø T	
2.	REST OF ALL COLUMNS (250 X 400)	8-16 Ø T	8-16 Ø T	8-16 Ø T	

**DEVELOPMENT LENGTH FOR BARS:**

DIA OF BAR(mm)	LENTH 'Ld'(mm)
12	800
16	1100

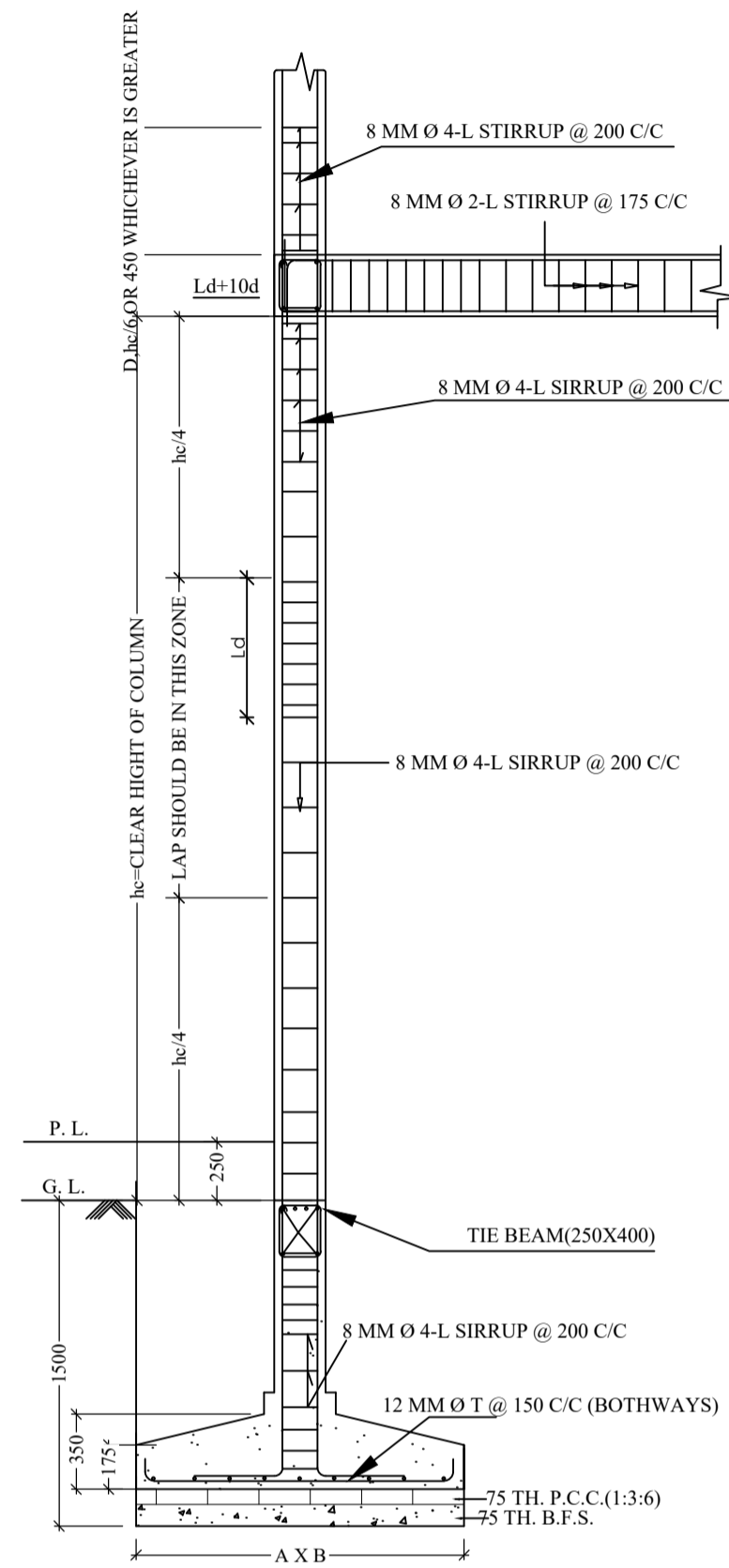
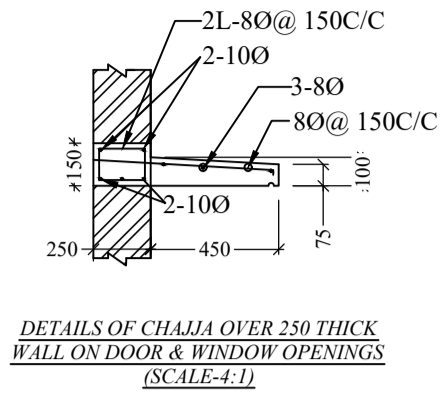

TYPICAL SECTIONAL ELEVATION OF COLUMN WITH DETAIL JOINT CONNECTION

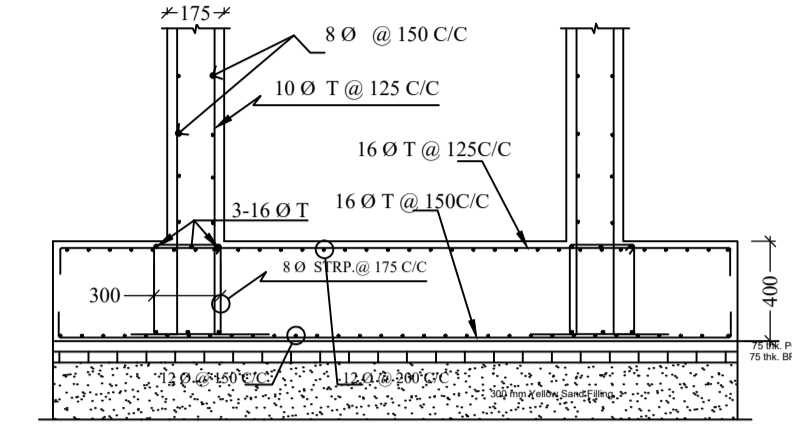

R/F DETAIL OF LIST FOUNDATION (NTS)

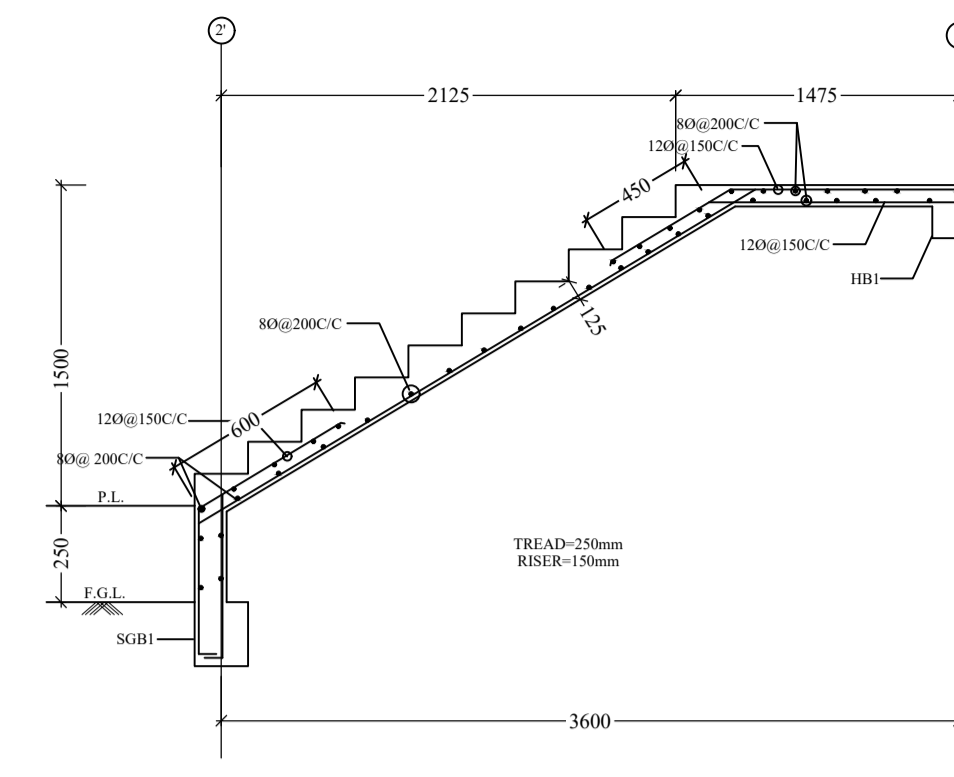

R/F DETAIL OF STAIRCASE (SCALE-3:1)

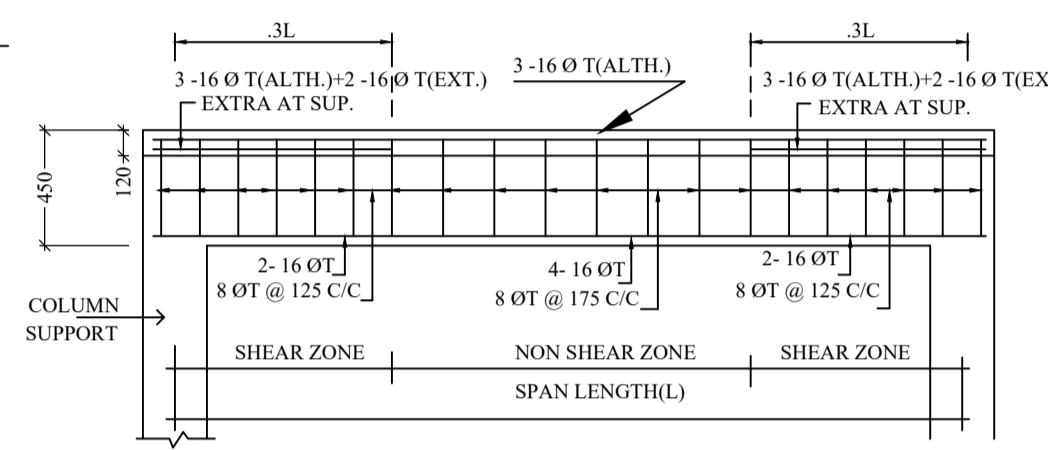

LONG SECTION OF R.C.C FLOOR BEAM (RB1)

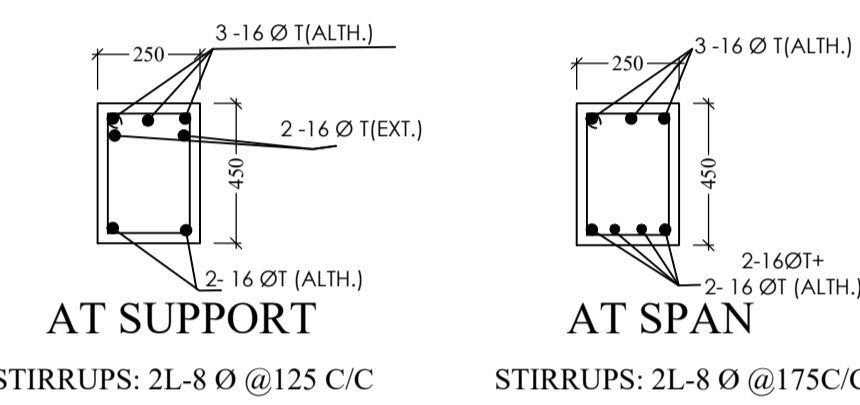

DETAIL OF RB1

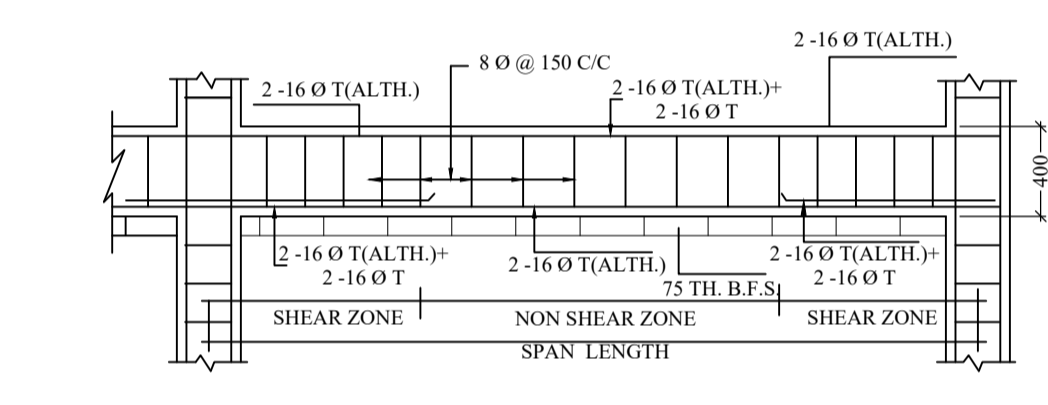

LONG SECTION OF R.C.C TIE BEAM (TB1)

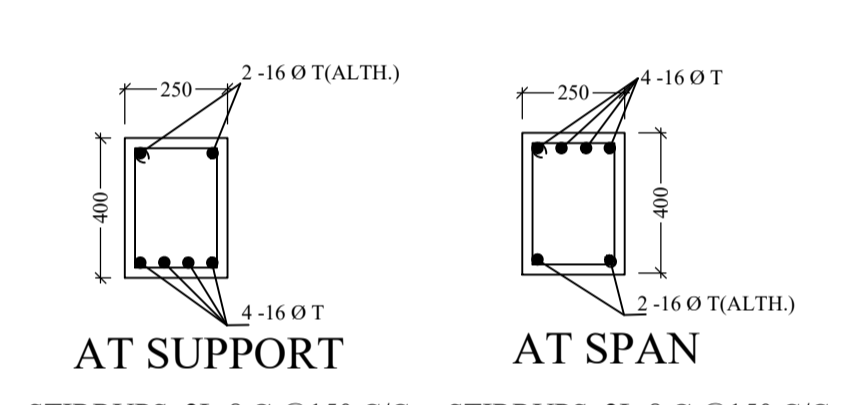

DETAIL OF TB1

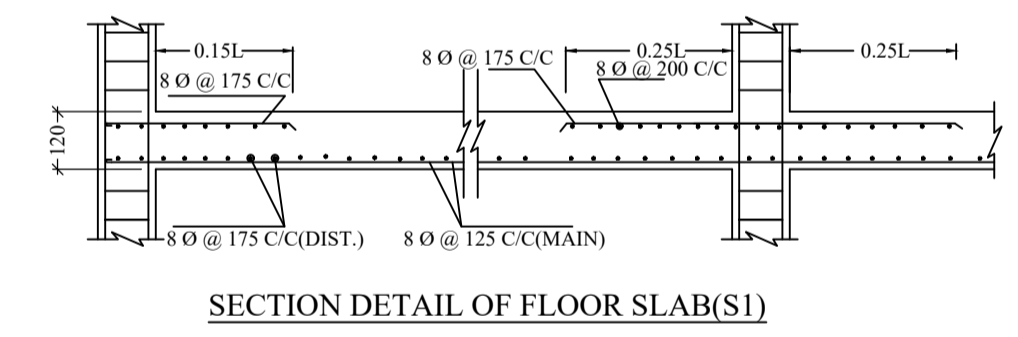

SECTION DETAIL OF FLOOR SLAB (S1)

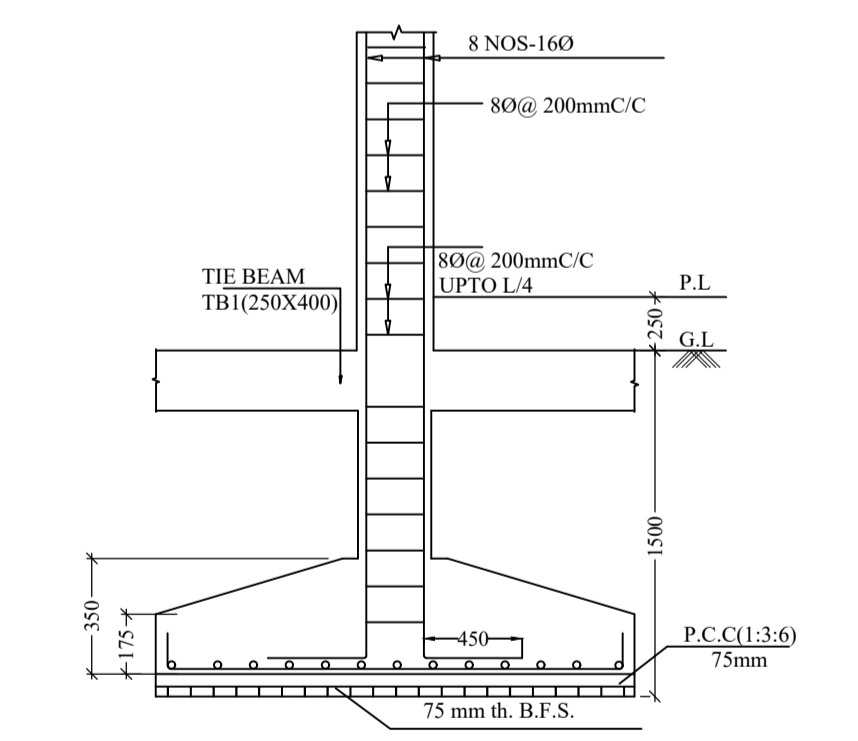

SECTION C-C

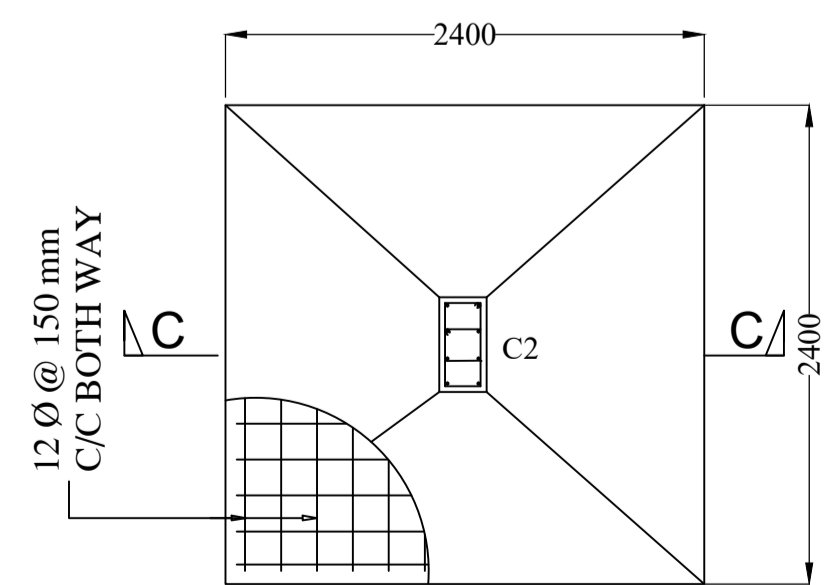

PLAN OF FOUNDATION DETAILS (F2) NOT TO SCALE

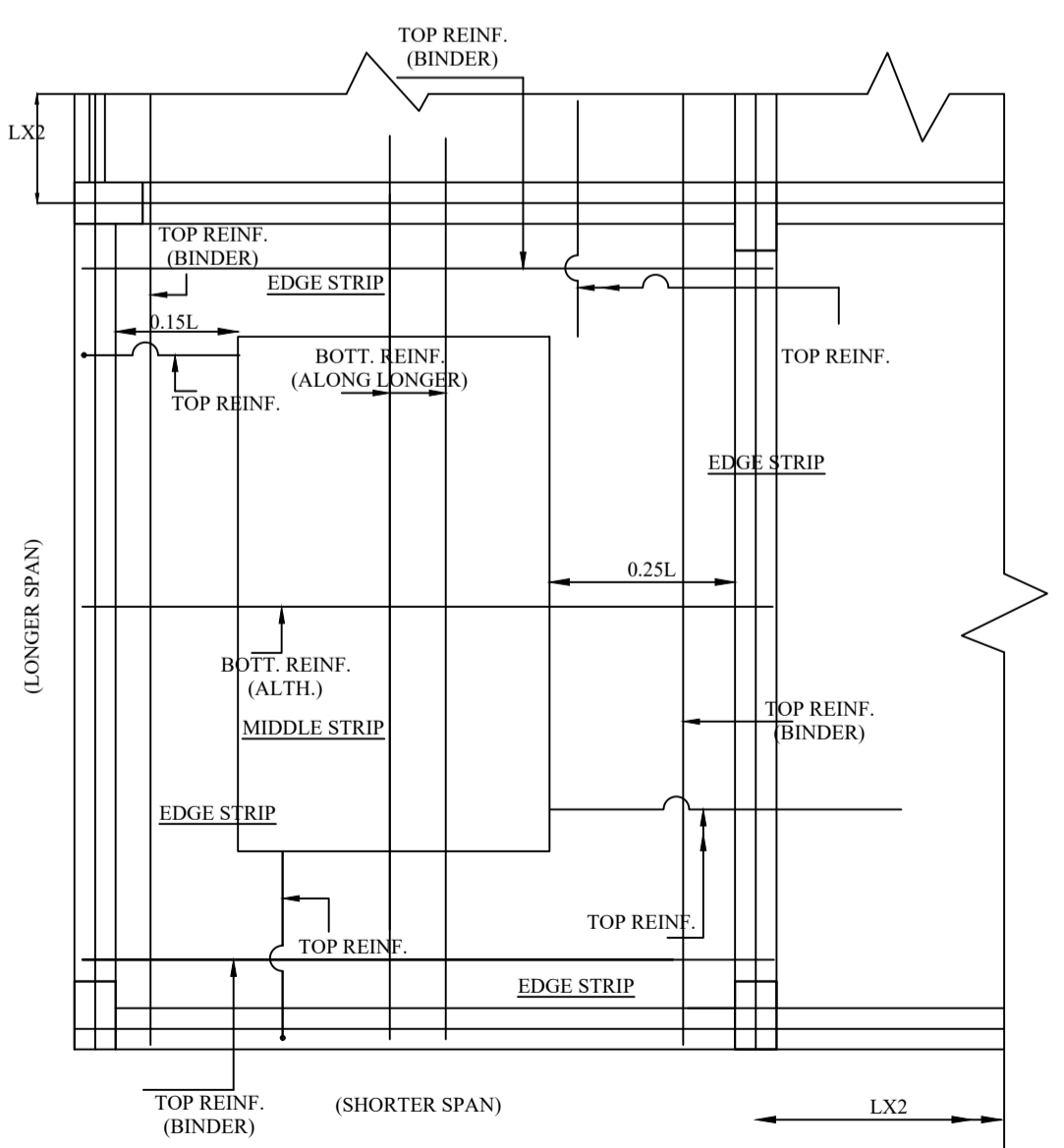

TYP. ARRANGEMENT OF REINFORCEMENT IN SLAB PANEL NOT TO SCALE

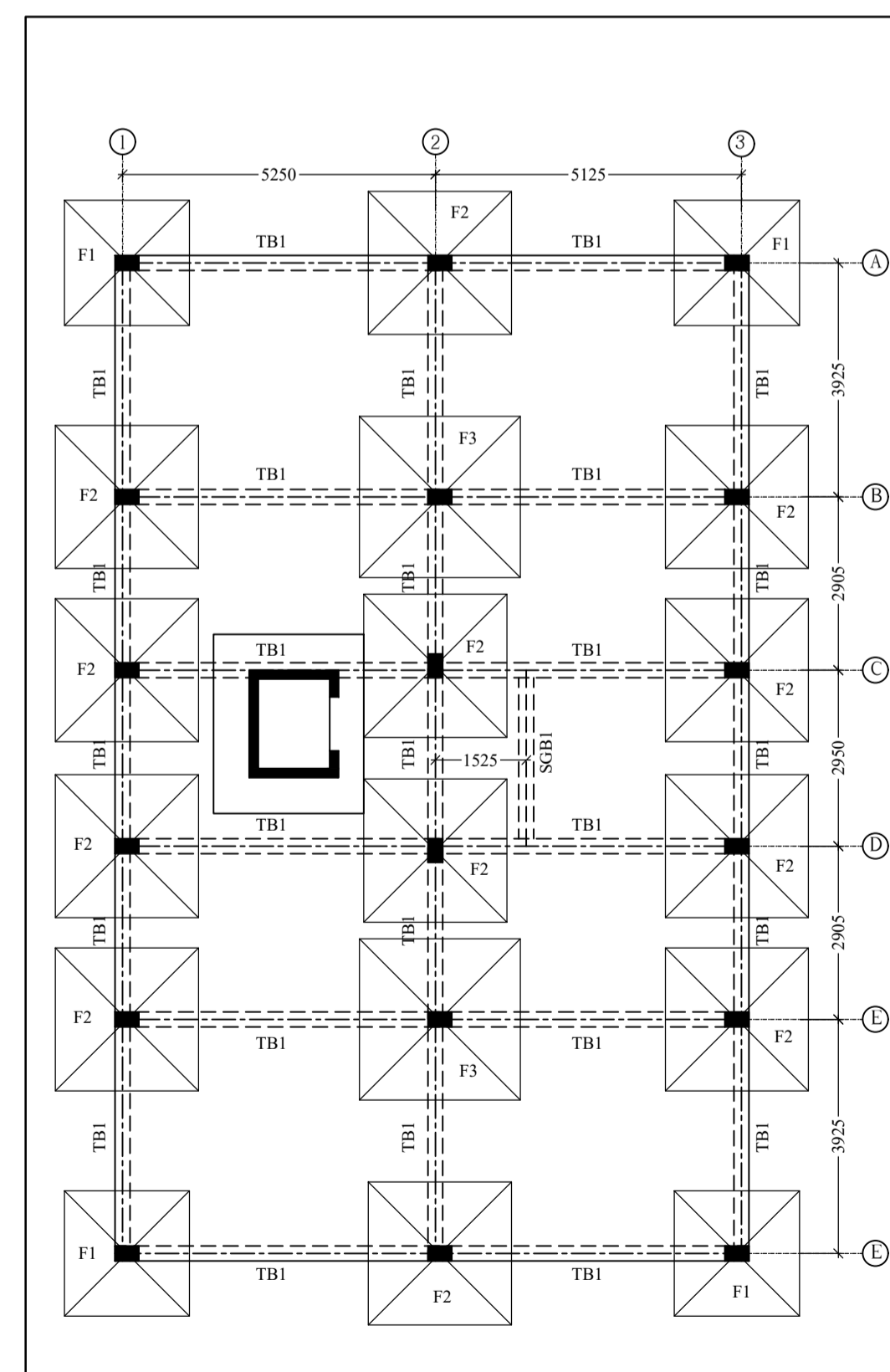

FOUNDATION, TIE BEAM LAYOUT PLAN (SCALE-1:1)

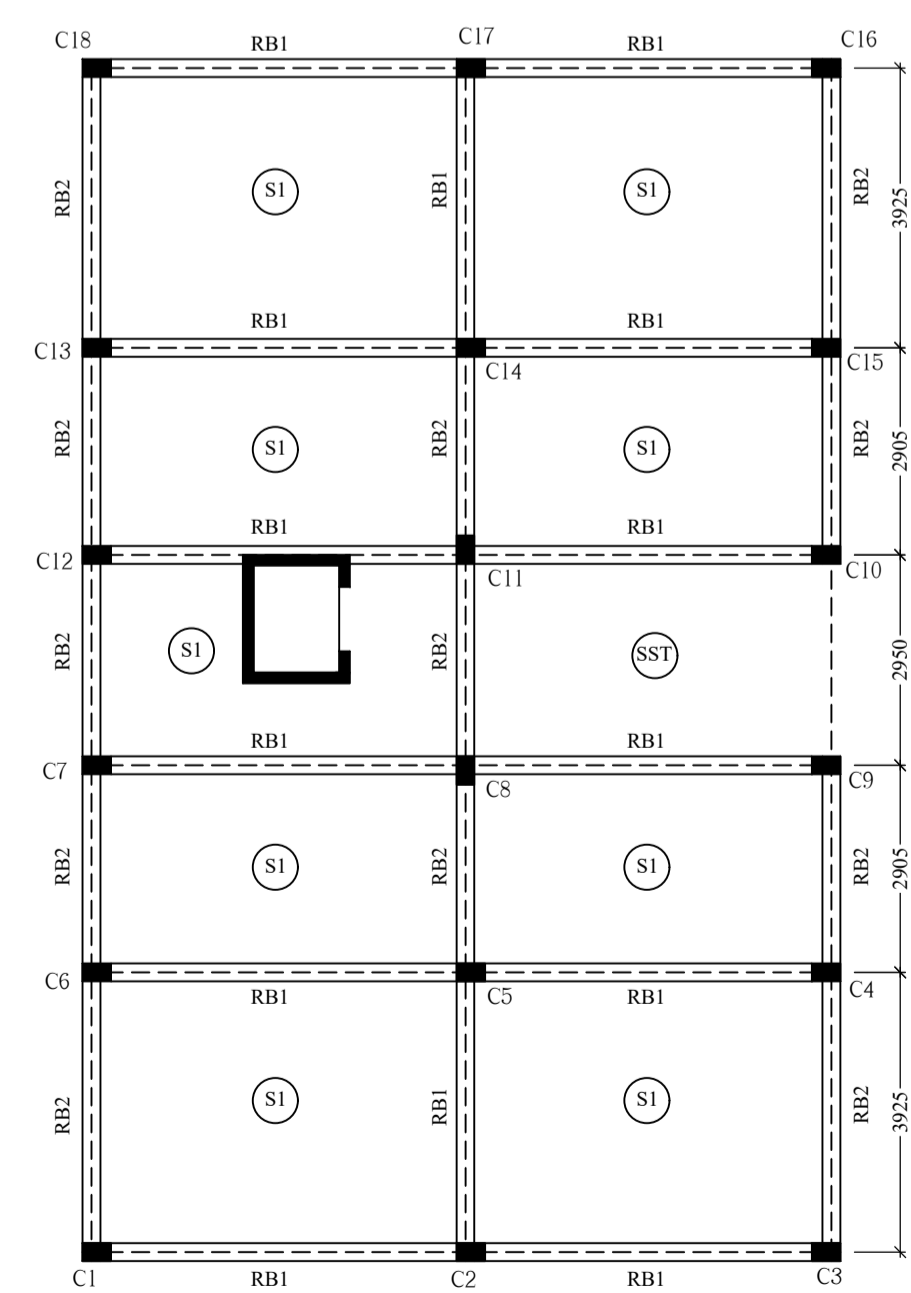

FLOOR COLUMN, BEAM, SLAB LAYOUT PLAN (SCALE-1:1)

PROPOSED STRUCTURAL PLAN OF G+4 STORIED RESIDENTIAL BUILDING OVER THE LAND AT MOUZA- NATAGARH, R.S. NO.-101, TOUZI NO.-155, R.S. & L.R. DAG NO.-1978, J.L. NO.-15, R.S. KHATIAN NO.-385, L.R. KHATIAN NO.-4645, WARD NO.-33, HOLDING NO.-493, AT BARASAT ROAD (PURBAYAN ROAD), DIST-NORTH 24 PARGANAS, P.S.-GHOLA, UNDER PANIHATI MUNICIPALITY.

NAME OF OWNERS:-

1) SMT. RANJANA SHAW

**DECLARATION OF STRUCTURAL ENGINEER:-**

WE HERE BY CERTIFY THAT THE FOUNDATION & SUPER STRUCTURE OF THE BUILDING PROPOSED FOR CONSTRUCTION, HAVE BEEN DESIGNED WITH ALL RELEVANT CODE PRACTICE TAKING UNDER CONSIDERATION INCLUDING BEARING CAPACITY OF SOIL, SETTLEMENT ETC. & IT IS HOWEVER SAFE & SOUND IN ALL RESPECT AS FAR OUR KNOWLEDGE GOES.

SIGNATURE OF STRUCTURAL ENGINEER

**DECLARATION OF ARCHITECT/L.B.S:-**

I/ WE DO HEREBY DECLARE THAT THE RESPECTIVE BUILDING HAS BEEN PLANNED & DESIGNED CONFORMING THE 'WBMBR,2007', 'NBC'. I/ WE ALSO RESPONSIBLE FOR KEEPING THE SANCTIONED DRAWING SAME DURING EXECUTION UNDER OUR SUPERVISION. THIS IS ALSO CERTIFIED THAT THE SAME WILL BE SAFE & SOUND IN ALL RESPECT.

SIGNATURE OF L.B.S

**DECLARATION OF OWNER:-**

CERTIFIED THAT I/WE SHALL NOT ON OR LATER DATE MAKE ANY ADDITION OR ALTERATION TO THIS PLAN SO AS TO CONVERT IT FOR MY/OUR USE OR ALLOW IT TO BE USED FOR SEPERATE FLATS PER FLOOR/STOREY. CERTIFIED THAT I/WE HAVE GONE THROUGH BUILDING RULES FOR THE PANIHATI MUNICIPALITY AND ALSO UNDERTAKE TO ABITE BY THOSE RULES DURING AND AFTER CONSTRUCTION OF THE BUILDING. CERTIFIED THAT I/WE ALSO UNDERTAKE TO REPORT OF COMMENCEMENT BEFORE SEVEN DAYS AND COMPLETION WOULD BE REPORTED WITHIN THIRTY DAYS.

SIGNATURE OF OWNER

**NOTES :-**

- ALL DIMENSIONS AND LEVELS ARE IN mm UNTIL OTHERWISE STATED
- (± 00) LEVEL CORRESPONDS TO FINISHED GROUND LEVEL AND ROAD CROWN LEVEL
- LAP LENGTH / DEVELOPMENT LENGTH / BOND LENGTH OF REINF. SHALL BE 50 - (dia. OF REINFORCEMENT) (LARGER IF ANY)
- CLEAR COVER TO MAIN REINF. SHALL BE AS FOLLOWS :- (1) for slab 20 mm (bottom) & 20mm (top), (2) for beams 25 mm, (3) for columns 40 mm.
- ALL STRUCTURAL CONC. GRADE SHALL BE M20 (1:1.5:3) BY VOLUME UNLESS OTHERWISE STATED.
- REINFORCEMENT SHALL BE OF Fe-500 GRADE CONFORMING TO B.S.1786
- READ THIS DRAWING IN CONNECTION WITH THE ARCHITECTURAL DRAWING.
- FOR ANY DISCREPANCY CONCERNED, OUR SITE ENGINEER SHALL BE CONSULTED WITH.
- COLUMN LINKS SHALL BE PLACED CONTINUOUS THROUGH BEAM-COLUMN JUNCTION BUT STIRRUPS - SHALL BE STARTED FROM THE COLUMN FACE ONLY.
- LEVEL SHOWN ALONG WITH THE SLAB/BEAM MARKINGS DENOTES THE TOP LEVEL OF SLABS&BEAMS.
- EXTRA TOP BARS OVER SUPPORT FOR BEAMS & SLABS SHOULD BE PROVIDED (UPTO L/3) FROM SUPPORT FACE CONSIDERING (L) AS C/C DISTANCE BETWEEN THE SUPPORTS.
- RECRON 3S FIBRE MUST BE MIXED WITH M20 CONCRETE 0.2% BY WEIGHT OF CEMENT

L.B.S/ENGINEER:-  
Sk. Nasir Uddin  
L.B.S-I  
(Panihati Municipality)  
Contact: +917450876192

STRUCTURAL ENGINEER:-  
Mr. Rany Dutta  
Structural-II  
(Panihati Municipality)  
Contact: +919830413729

GEOTECH ENGINEER:-  
Mr. Anjan Kumar Kar  
Geotech-I  
(Panihati Municipality)  
Contact: +919830961774

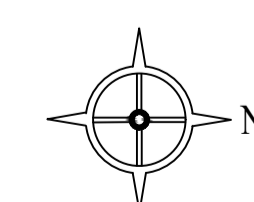

RD/RS/STRUC/001

10.10.2022

DRAWING NO.

DATE

R. DUTTA

R. DUTTA

R. DUTTA

DRAWN BY:

CHECKED BY:

APPROVED BY:

**DRWAING TITLE:-**

DETAIL STRUCTURAL PLAN OF FOUNDATION, LAB LAYOUTS, SECTIONS OF FOOTING, SLAB, FLOOR & TIE BEAM, LIFT WELL & FOOTING, LINTEL & CHAJJA WITH R/F DETAILS.

